

SEAWATER INTAKE $\phi$ 25

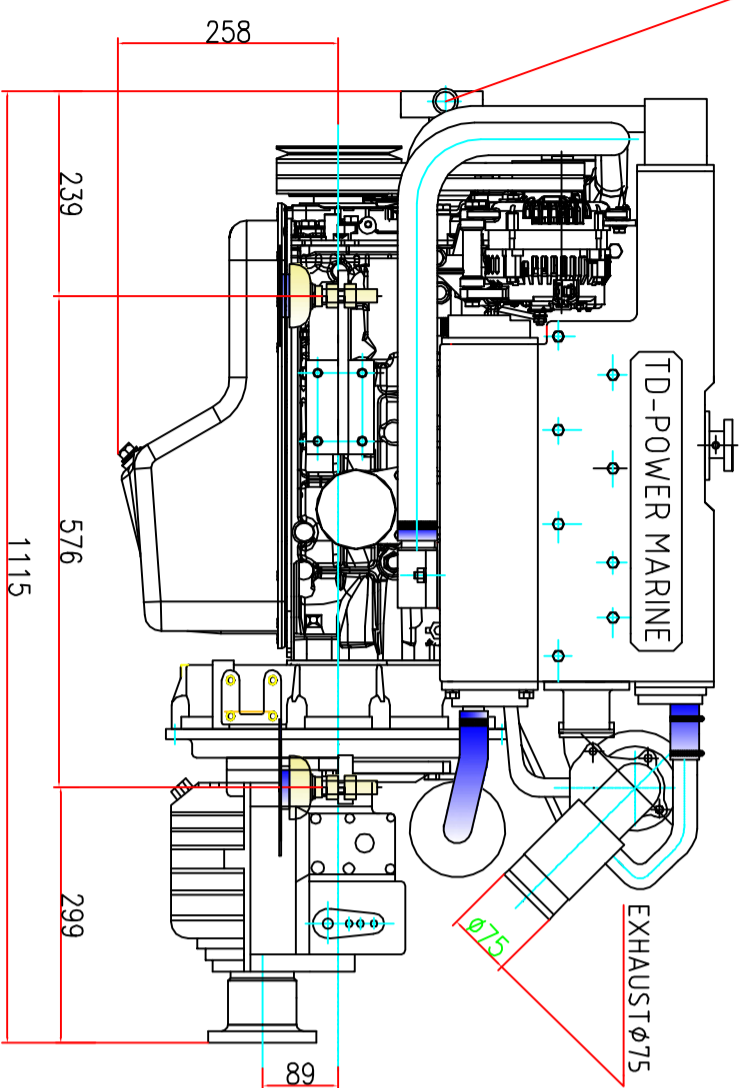

Generated by Foxit PDF Creator © Foxit Software  
<http://www.foxitsoftware.com> For evaluation only.

Main technical specifications

Model	TDME-498	TDME-498T	TDME-498Ti
Type	Vertical, water-cooling, 4-stroke direct-injection combustion chamber		
No. of cylinders	4		
Borexstroke(mm $\times$ mm)	98X105		
Total displacement(L)	3.168		
Rate power(HP/r/min)	85/3600	110/3200	120/3200
Max. torque(N.m)	$\approx$ 196	$\approx$ 275	$\approx$ 300
Alternator	12V/70A		
Marine gear box	H100D	H130	
Reduction ratio	1.88:1 2.73:1	2:1 2.5:1	
Transmission	Hydraulic		
Installation angle	$\leq$ 20°		
Net weight(Kg)	345	360	385

